

**Four-wheel drive
for tough applications**

- Rated Capacity Limiter ... Standard
- Capacity on Outriggers ... 4,080 kg
- Pick and Carry Capacity ... up to 3,260 kg
- Height ... 2.06 m
- Width ... 1.63 m
- Boom Rotation ... 360 Degree Continuous
- Sheave Height ... up to 10.21 m
- Horizontal Reach ... up to 8.28 m
- Tight Turning Radius
- 4-Wheel Steer ... Standard
- 4-Wheel Drive ... Standard
- Fully Hydraulic Controls for Smooth Precise Operations
- Independent Outrigger Controls
- Dual Fuel or Diesel Available

BRODERSON
Manufacturing Corp.



IC-40-2B

CAPACITIES APPLY TO OPERATION ON FIRM LEVEL SURFACE									
LOAD RADIUS METERS	MAIN BOOM OR EXTENSION CAPACITIES IN KILOGRAMS								
	360° ROTATION		OVER FRONT						
	ON RUBBER	ON OUTRIGGERS	ON RUBBER	ON OUTRIGGERS					
MAIN BOOM	1.2	3170	3850	3260	4080				
	1.5	2320	3220	2750	3220				
	2.0	1450	2390	2250	2400				
	2.5	990	1830	1830	1830				
	3.0	680	1560	1480	1560				
	3.5	500	1350	1170	1350				
	4.0	430	1160	940	1180				
	4.5	380	980	810	1050				
	5.0	330	830	700	960				
	5.8	270	660	520	840				
2.44M BOOM EXTENSION	6.0	260	660	520	750				
	6.5	220	600	480	680				
	7.0	190	520	420	620				
	7.5	170	450	370	570				
	8.2	130	340	290	500				
	BOOM EXTENSION	2.44M BOOM EXTENSION - STRAIGHT OR OFFSET							
	ANGLE	MAIN BOOM ANGLE							
		0°	10°	20°	30°	40°	50°	60°	70°
	+* 0°	500	540	590	660	720	840	1040	1590
	* 15°	—	—	500	560	610	680	770	930
* 30°	—	—	—	500	540	590	660	720	

+ USE 0° FOR STRAIGHT BOOM EXTENSION.

* USE 0°, 15° OR 30° FOR OFFSET BOOM EXTENSION.

CAUTION: BOOM EXTENSION LOADS MUST NOT EXCEED MAIN BOOM CAPACITY. BOOM EXTENSION DEDUCT: 45 KG WHEN STOWED ON BASE BOOM. DO NOT PICK & CARRY WITH LOADS ON BOOM EXTENSION.

CAPACITIES ON OUTRIGGERS ARE 85% OF TIPPING LOADS. CAPACITIES ON RUBBER ARE 75% OF TIPPING LOADS. CAPACITIES BELOW **BOLD** LINE ARE LIMITED BY TIPPING. OTHER CAPACITIES ARE LIMITED BY STRUCTURAL OR HYDRAULIC CAPABILITIES. MAXIMUM HYDRAULIC PRESSURE 179 BAR.

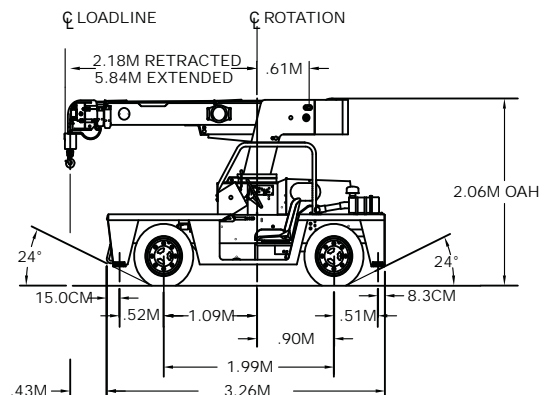
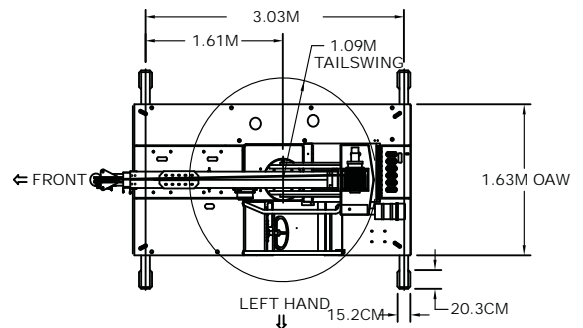
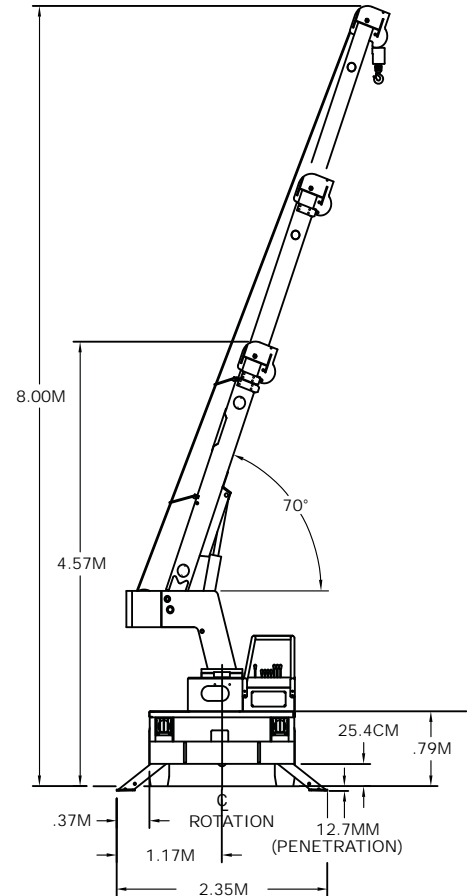
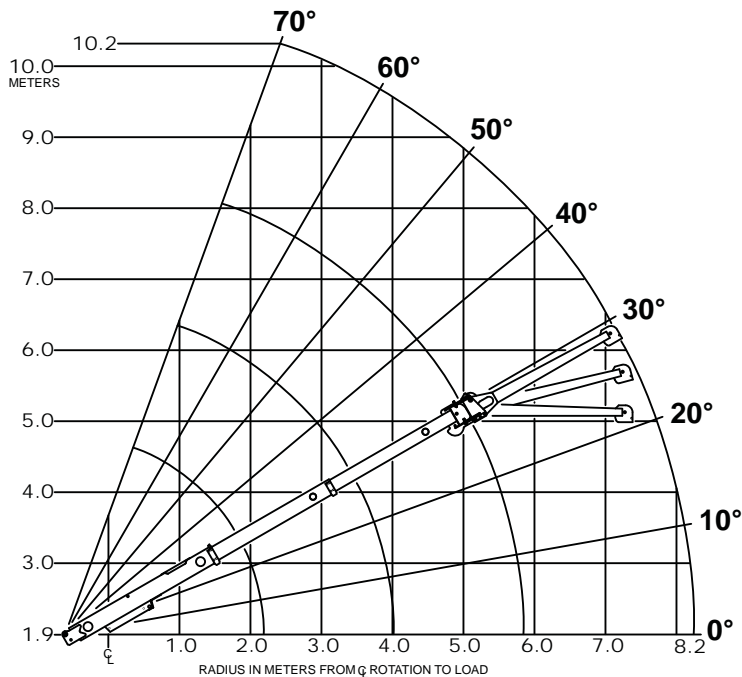
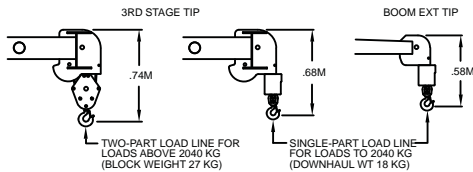

IC-40-2B

Specifications

GENERAL:

Weight	4,050 kg
Travel Speed	0 to 16 kp/h
Drawbar Pull	910 kg
Gradeability:	24%
Boom Movement:	
Rotation	Continuous
Elevation	0° to 70°
Extension	2.18 m to 5.84 m
Boom Speeds:	
Rotation	1.4 RPM
Elevation	17 seconds
Extension	32 seconds

ENGINE:

Make	GM	Cummins
Model	2.4 L EFI	A2300
Type	Dual Fuel	Diesel
No. Cyl.	4	4
Displacement	2.4 L	2.3 L
HP @ Gov. Speed	48 kw	34 kw
EPA Certification	Tier 2	Tier 4
Fuel Tank Capacity	51 L	

HYDROSTATIC PUMP:

Piston type, direct driven from engine crankshaft. Maximum flow 129 LP/M. Maximum pressure 276 bar.

AXLES:

Front Axle:

Planetary drive/steer axle with 16.15:1 ratio. Differential equipped with "limited slip" feature. Axle is rigidly mounted to frame.

Rear Axle:

Planetary drive/steer axle with 16.15:1 ratio. Differential is "limited slip" in rear axle. 1-1/2 degree oscillation in either direction.

STEERING:

Hydraulic steering unit with a cylinder attached to each axle. Rear axle is the primary steer. An electric switch on the operator's compartment is used to select rear-wheel steering, four-wheel steering round steer or crab steering. Electronic sensors & control box automatically align the steering when a new mode is selected.

BRAKES:

Primary braking from hydrostatic transmission. Foot-actuated wet-disc brakes in each axle for additional braking in some conditions. Lever-actuated parking brake to hold crane when not being driven

TIRES:

28x9-15 pneumatic tires. Pressurized to 120 PSI for crane rated loads.

CHASSIS:

CARGO DECK:

2.7 m² of deck area. 2,720 kg capacity on deck when load is centered over or between axles.

CHASSIS: (Cont'd)

OUTRIGGERS:

Four hydraulic outriggers of box-beam construction. Independent controls for each. Hydraulic cylinders are equipped with direct-connected holding valves.

Lifting Rings

Lifting rings at each corner of cargo deck so sling can be attached for lifting crane.

Pulling Eye

Mounted on front bumper.

OPERATOR COMPARTMENT:

Provides one-position access to all chassis & crane functions. Includes adjustable operator's seat, retracting seat belts, fire extinguisher & bubble level.

ELECTRICAL:

12 Volt System

Lighting Package:

One pair headlights and one pair taillights.

Instrument Package:

Fuel, ammeter, oil pressure, and water temperature gauges, hydraulic oil temperature gauge and hourmeter.

Back-Up Alarm:

Provides pulsating sound from 97dB alarm when transmission is in reverse.

Outrigger Alarm System:

Two-tone alarm is activated when "outrigger down" or "outrigger out" controls are operated.

HYDRAULIC SYSTEM:

Tandem pump mounted to rear of hydrostatic piston pump. Delivers 23 LP/M at 179 bar for boom circuits and 64 LPM at 172 bar for hoist circuit. System protected by relief valves. Hydraulic oil reservoir has 53 liter capacity.

BOOM ASSEMBLY:

Three-section boom assembly equipped with bearing pads, double-acting hydraulic cylinders extends boom. The primary extension cylinder and the double-acting boom elevation cylinder are equipped with direct connected holding valves. Boom angle indicator on side of boom.

Boom Rotation:

Heavy-duty ball bearing rotation gear with external teeth. Rotation is powered by hydraulic motor & worm gear drive.

Boom Hoist:

Turret mounted planetary gear hoist hydraulically powered with a bare drum line pull of 2,270 kg & a line speed of 26 MP/M. Hoist includes 26 m of 9.5 mm wire rope, downhaul weight, swivel hook and sheave block for 2-part line.

Anti-Two-Block Device:

Prevents damage to hoist rope and/or crane components from pulling load hook against tip.

Rated Capacity Limiter:

Warns operator of impending overload with audible & visual signals. Prevents overload by stopping boom functions that cause overloads.

IC-40-2B

Options

Listed below are brief descriptions of options available for this product.
Consult the IC-40-2B Engineering Spec for additional information.

MODEL:

IC-40-2B Industrial Crane

ENGINE OPTIONS:

Spark Arrester Muffler

Installed in addition to std. muffler.

Engine Shut Down Gauges

Shuts engine off when high water temperature or low engine oil pressure occurs for diesel only.

TIRE OPTIONS:

Foam Filling of Tires

Spare Tire & Wheel, pneumatic

Foam Filling of Spare Tire

CHASSIS OPTIONS:

Auxiliary Winch

Mounted behind the front bumper, hydraulically driven with control in operator's console (1,360 kg @ 6.10 mp/m).

Pintle Hook - Rear

Holland "T-60-A" pintle hook mounted on rear of frame. 4,500 kg capacity.

Lifting Sling

Sling to attach to Lifting Rings.

Headlight & Taillight Grilles

Welded steel protective grilles for headlights and taillights.

Rearview Mirrors

One mounted on right-hand deck stake and one mounted on left-hand deck stake.

OPERATOR COMPARTMENT

OPTIONS:

All Weather Cab

Rigid-mounted canopy section and removable hinged door with safety glass. Cab door adds 2. in to crane on operator's side. Includes heater, electric windshield wiper, one sliding glass window in the door, & one fold out window in rear. Defroster fan & dome light included.

Cab Heater Only

Heater with two-speed fan for units without All Weather Cab.

Operator Guard

Tubular steel weldment with heavy expanded steel mesh top section for units without All Weather Cabs.

ELECTRICAL OPTIONS:

Strobe Lights

Yellow strobe light mounted on each side of turret weight box.

Boom Work Lights

One work light mounted to boom to light boom tip and one work light mounted to turret to light ground under boom tip.

BOOM ATTACHMENTS:

Boom Extension

2.44 m, boom stowable

Boom Extension, Offset

2.44 m, boom stowable. Boom extension is offsettable to 3 different positions; 0 degree (in line), 15 degree and 30 degree offset.

Searcher Hook - Nose Mount:

907 kg capacity. Swivel hook with spring latch hangs from support structure projecting outward from boom tip.

Should you require an option or special equipment not listed please consult your dealer salesperson or BMC®.

BRODERSON

Manufacturing Corp.
14741 West 106th Street
Lenexa, KS 66215 USA

Tel (913) 888-0606
Fax (913) 888-8431
www.bmccranes.com

Dimensions and values shown are
for reference purposes only.
Specifications subject to change.

