

**8,160 kg Max. Capacity  
Available in 3 Boom  
Lengths**

- Rated Capacity Limiter ... Standard
- Capacity on Outriggers ... 8,160 kg
- Pick and Carry Capacity ... up to 5,300 kg
- Height ... 2.21 m
- Width ... 1.98 m
- Boom Rotation ... 360 Degree Continuous
- Sheave Height ... up to 14.22 m
- Horizontal Reach ... up to 12.19 m
- 4-Wheel Steer ... Standard
- 4-Wheel Drive ... Optional
- Powershift Transmission ... Standard
- Fully Hydraulic Controls for Smooth Precise Operations
- Independent Outrigger Controls
- Dual Fuel or Diesel Available

**BRODERSON**<sup>®</sup>  
Manufacturing Corp.



# IC-80-1H

CAPACITIES APPLY TO OPERATION ON FIRM LEVEL SURFACE					
LOAD RADIUS METERS	MAIN BOOM OR EXTENSION CAPACITIES IN KILOGRAMS				
	360° ROTATION		OVER FRONT		
	ON RUBBER	ON OUTRIGGERS	ON RUBBER	ON OUTRIGGERS	
MAIN BOOM	1.5	4350	7710	5300	8160
	2.0	3290	5980	4460	5980
	2.5	2520	4480	3710	4480
	3.0	1920	3540	2930	3540
	3.5	1500	3090	2260	3090
	4.0	1210	2710	1850	2710
	4.5	1010	2350	1580	2350
	5.0	870	2050	1360	2050
	5.5	760	1850	1190	1870
	6.0	670	1640	1060	1750
3 M BOOM EXT.	6.5	600	1390	950	1390
	7.0	530	1310	840	1310
	8.0	410	1110	660	1160
	9.1	300	900	520	1020
	3 METER BOOM EXTENSION - STRAIGHT OR OFFSET				
BOOM EXTENSION ANGLE	MAIN BOOM ANGLE				
	0°	30°	45°	60°	70°
* † 0°	1020	1180	1450	2260	3170
† 15°	---	1090	1220	1580	1900
† 30°	---	1020	1130	1360	1490

\* USE 0° FOR STRAIGHT BOOM EXTENSION.  
 † USE 0°, 15° OR 30° FOR OFFSET BOOM EXTENSION.

**CAUTION** BOOM EXTENSION LOADS MUST NOT EXCEED MAIN BOOM CAPACITY.  
 DO NOT PICK & CARRY WITH LOADS ON BOOM EXTENSION.

CAPACITIES ON OUTRIGGERS ARE 85% OF TIPPING LOADS. CAPACITIES ON RUBBER ARE 75% OF TIPPING LOADS. CAPACITIES BELOW BOLD LINE ARE LIMITED BY TIPPING. OTHER CAPACITIES ARE LIMITED BY STRUCTURAL OR HYDRAULIC CAPABILITY.

BOOM EXTENSION DEDUCT: 45 KGS WHEN STOWED ON BASE BOOM.

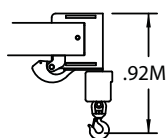
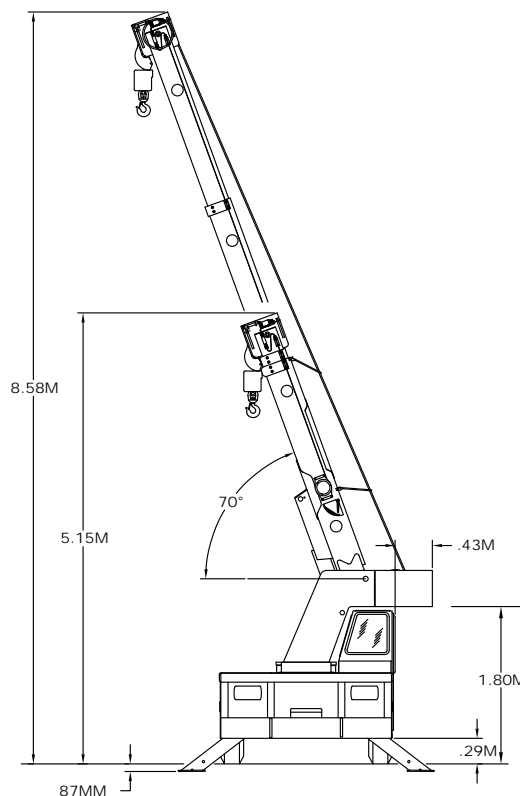

USE SINGLE PART LOAD LINE FOR LOADS TO 4090 KGS. (WT. 40 KGS.)

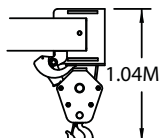

USE TWO PART LOADLINE FOR LOADS TO 8180 KGS. (WT. 56 KGS.)

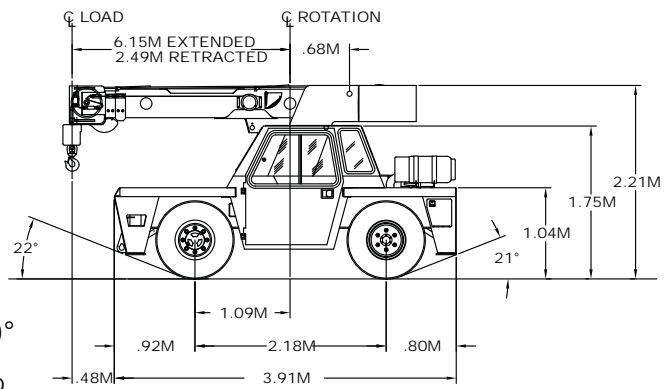
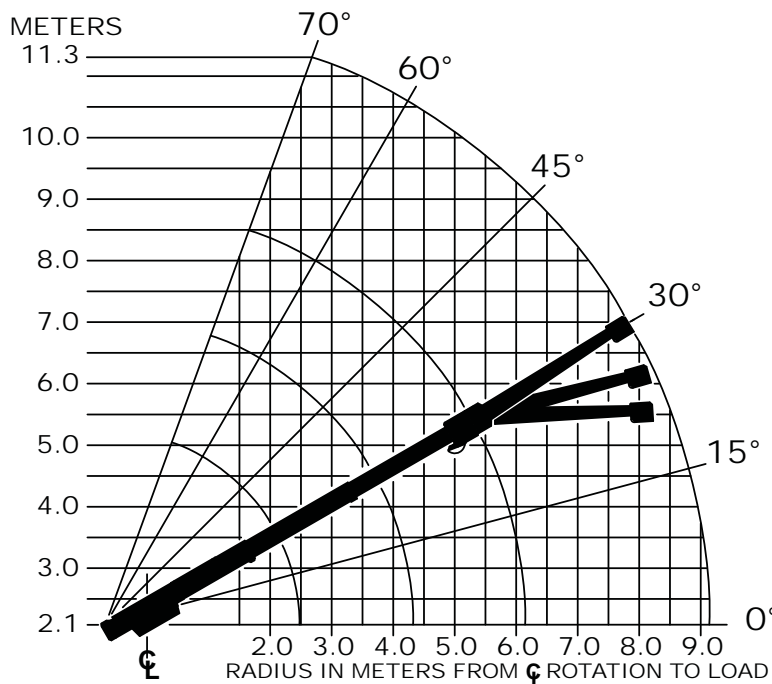
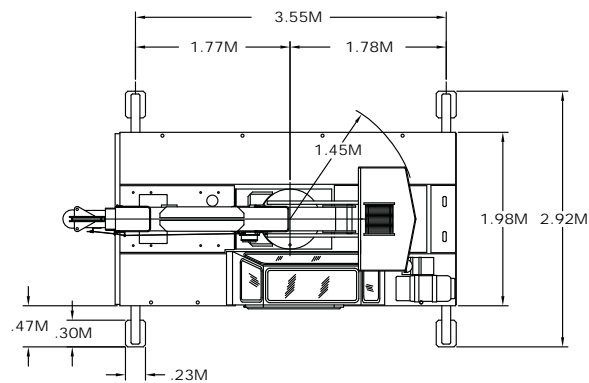

# IC-80-2H

## CAPACITIES APPLY TO OPERATION ON FIRM LEVEL SURFACE

LOAD RADIUS METERS	MAIN BOOM OR EXTENSION CAPACITIES IN KILOGRAMS					
	360° ROTATION		OVER FRONT			
	ON RUBBER	ON OUTRIGGERS	ON RUBBER	ON OUTRIGGERS		
<b>MAIN BOOM</b>	1.5	4310	7710	5260	8160	
	2.0	3250	6020	4380	5990	
	2.5	2480	4480	3640	4500	
	3.0	1860	3540	2870	3540	
	3.5	1460	3090	2260	3090	
	4.0	1170	2720	1830	2720	
	4.5	980	2340	1520	2340	
	5.0	830	2010	1290	2000	
	5.5	720	1780	1130	1830	
	6.0	630	1560	1000	1680	
	6.5	550	1400	880	1550	
	7.3	450	1150	750	1400	
	<b>3 M BOOM EXT.</b>	8.0	380	1100	650	1230
		9.0	290	890	530	1060
10.0		220	740	430	920	
10.4		190	680	410	880	
3 METER BOOM EXTENSION - STRAIGHT OR OFFSET						
MAIN BOOM ANGLE						
ANGLE	0°	30°	45°	60°	70°	
*† 0°	1020	1180	1450	2260	3170	
† 15°	---	1090	1220	1580	1900	
† 30°	---	1020	1130	1360	1490	

\* USE 0° FOR STRAIGHT BOOM EXTENSION.

† USE 0°, 15° OR 30° FOR OFFSET BOOM EXTENSION.

**CAUTION** BOOM EXTENSION LOADS MUST NOT EXCEED MAIN BOOM CAPACITY. DO NOT PICK & CARRY WITH LOADS ON BOOM EXTENSION.

CAPACITIES ON OUTRIGGERS ARE 85% OF TIPPING LOADS. CAPACITIES ON RUBBER ARE 75% OF TIPPING LOADS. CAPACITIES BELOW BOLD LINE ARE LIMITED BY TIPPING. OTHER CAPACITIES ARE LIMITED BY STRUCTURAL OR HYDRAULIC CAPABILITY.

BOOM EXTENSION DEDUCT: 45 KGS WHEN STOWED ON BASE BOOM.

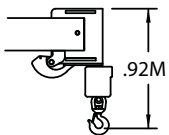
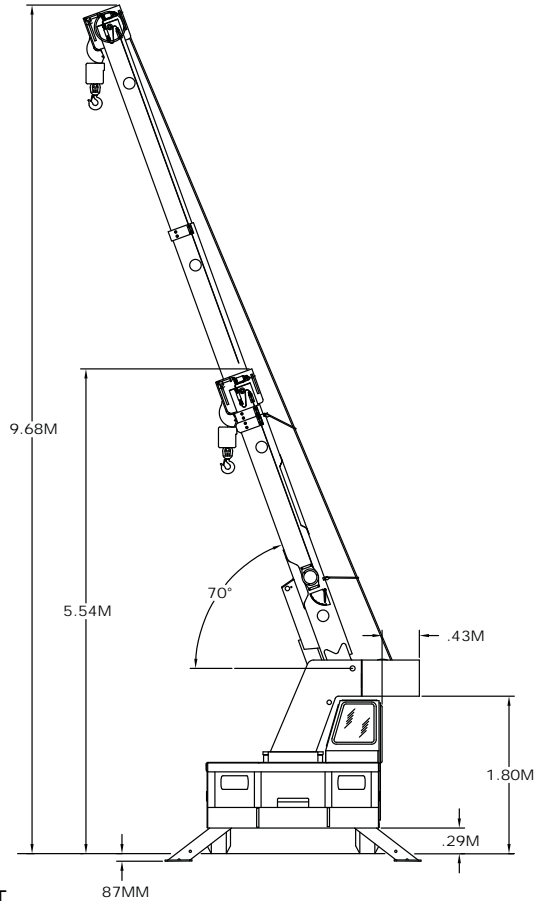

USE SINGLE PART LOAD LINE FOR LOADS TO 4090 KGS. (WT. 40 KGS.)

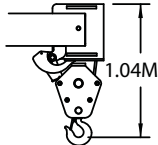

USE TWO PART LOADLINE FOR LOADS TO 8180 KGS. (WT. 56 KGS.)

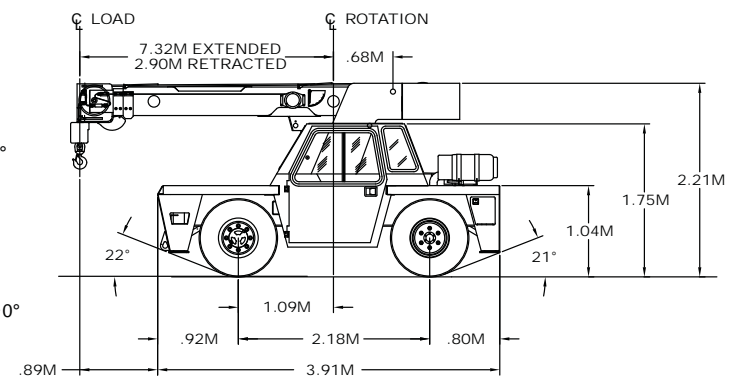
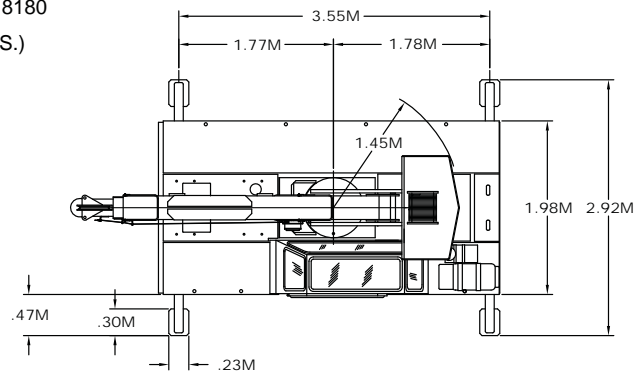
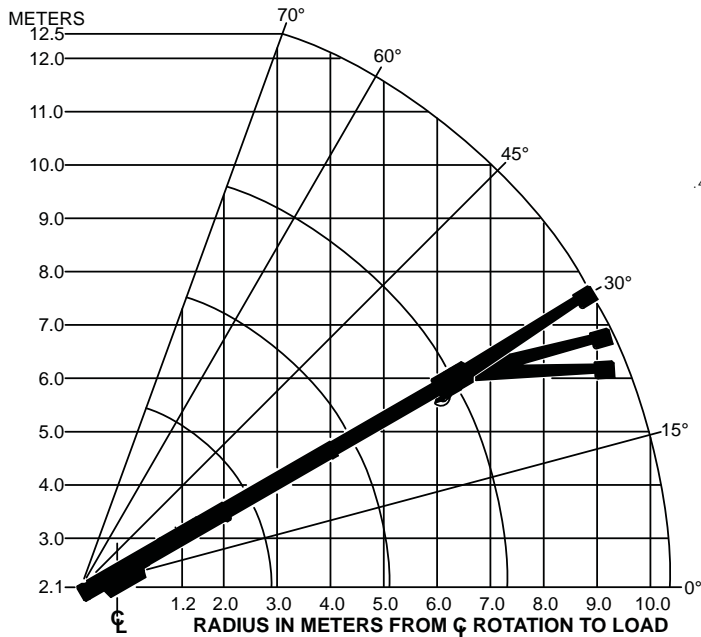

# IC-80-3H

CAPACITIES APPLY TO OPERATION ON FIRM LEVEL SURFACE					
	LOAD RADIUS METERS	MAIN BOOM OR EXTENSION CAPACITIES IN KILOGRAMS			
		360° ROTATION		OVER FRONT	
		ON RUBBER	ON OUTRIGGERS	ON RUBBER	ON OUTRIGGERS
MAIN BOOM	1.5	4260	7710	5170	8160
	2.0	3140	5790	4290	5790
	2.5	2470	4400	3580	4400
	3.0	1990	3560	2830	3560
	3.5	1560	2910	2180	2910
	4.0	1270	2520	1720	2520
	4.5	1060	2210	1400	2210
	5.0	890	1950	1170	1950
	5.5	740	1760	990	1760
	6.0	630	1570	840	1570
	6.5	540	1430	730	1430
	7.0	480	1330	650	1330
	7.5	430	1200	580	1230
	8.0	380	1090	530	1140
	8.5	340	1000	500	1070
9.0	290	910	460	990	
3M BOOM EXT.	10.0	180	760	390	850
	11.0	110	650	310	740
	12.2	60	520	220	630
	BOOM EXTENSION - STRAIGHT OR OFFSET				
MAIN BOOM ANGLE					
ANGLE					
0°					
30°					
45°					
60°					
70°					
*† 0°					
† 15°					
† 30°					

\* USE 0° FOR STRAIGHT BOOM EXTENSION.  
 † USE 0°, 15° OR 30° FOR OFFSET BOOM EXTENSION.

**CAUTION** BOOM EXTENSION LOADS MUST NOT EXCEED MAIN BOOM CAPACITY. DO NOT PICK & CARRY WITH LOADS ON BOOM EXTENSION.

CAPACITIES ON OUTRIGGERS ARE 85% OF TIPPING LOADS. CAPACITIES ON RUBBER ARE 75% OF TIPPING LOADS. CAPACITIES BELOW BOLD LINE ARE LIMITED BY TIPPING. OTHER CAPACITIES ARE LIMITED BY STRUCTURAL OR HYDRAULIC CAPABILITY.

BOOM EXTENSION DEDUCT: 45 KGS WHEN STOWED ON BASE BOOM.

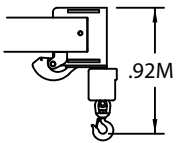

USE SINGLE PART LOAD LINE FOR LOADS TO 4090 KGS. (WT. 40 KGS.)

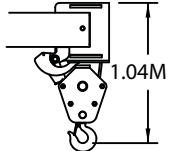

USE TWO PART LOADLINE FOR LOADS TO 8180 KGS. (WT. 56 KGS.)

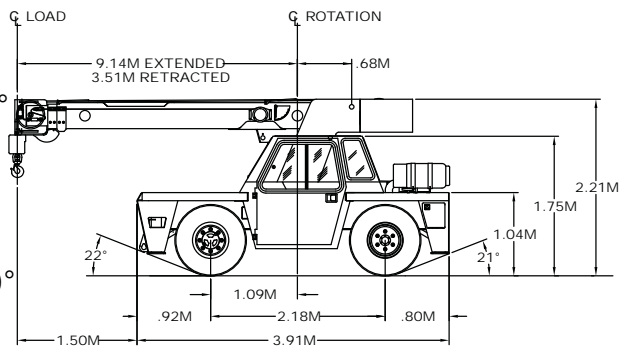
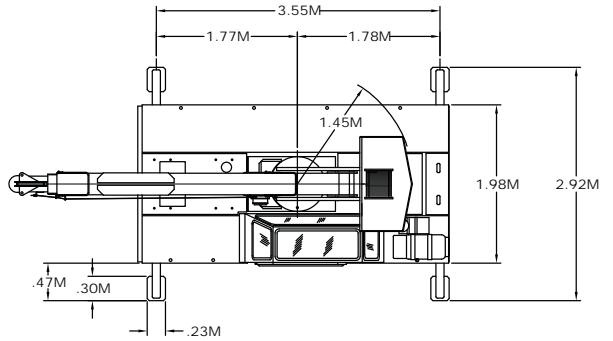
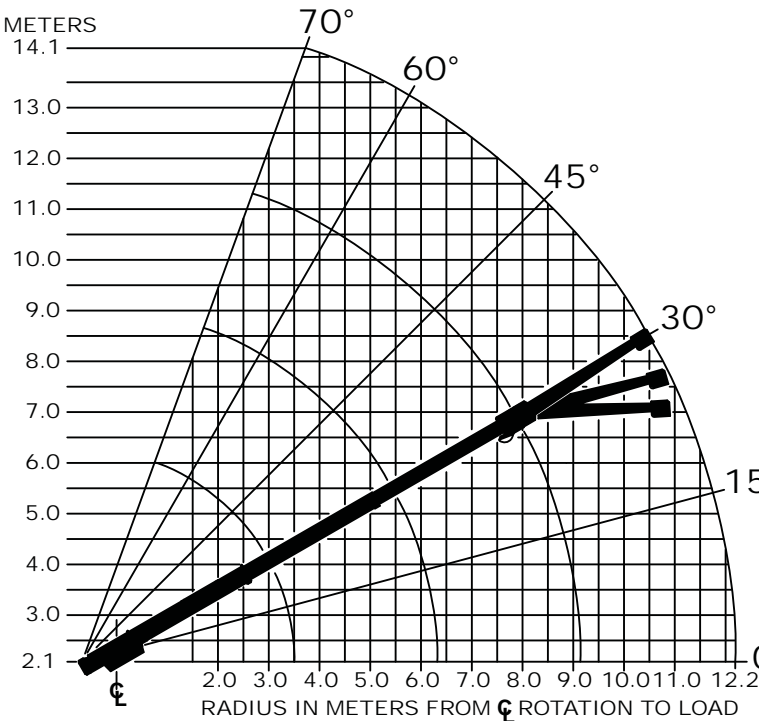
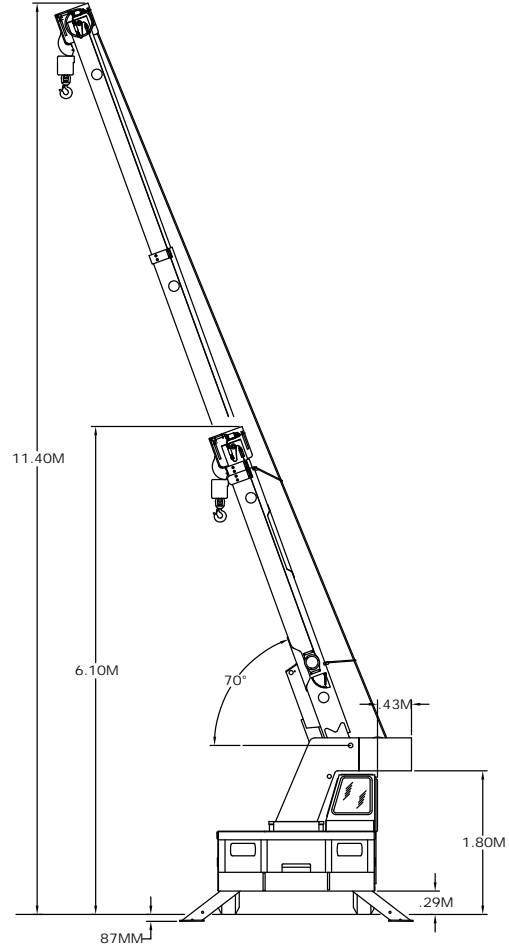

# IC-80-H

## Specifications

### GENERAL:

Weight:	IC-80-1H	IC-80-2H	IC-80-3H
4-Wheel Steer	7,325 kg	7,415 kg	7,600 kg
4-Wheel Drive	7,710 kg	7,800 kg	7,985 kg
<b>Boom Movement:</b>			
Rotation	Continuous	Continuous	Continuous
Elevation	0° to 70°	0° to 70°	0° to 70°
Extension	3.66 m	4.42 m	5.64 m
<b>Boom Speeds:</b>			
Rotation	2.0 RPM	2.0 RPM	2.0 RPM
Elevation	10.0 sec.	10.0 sec.	10.0 sec.
Extension	17.0 sec.	21.0 sec.	27.0 sec.
<b>Turning Radius:</b>			
(C/L of Outside Steering Wheel)		3.05 m	
Aisle Width for 90° Turn:		2.90 m	

### ENGINE:

Make	GM	Cummins
Model	3.0 EFI*	QSB 3.3L EPA Tier 3
Type	Gas	Diesel
No. Cyl.	4	4
Displacement	3.0 L	3.3 L
HP @ Gov. Speed	51.4 kw	63.4 kw
*Electronic Fuel Injection with Dual Fuel, US EPA & CARB Certified for 2005 Emissions Standards		
Fuel Tank Capacity:	6.66 L	

### TRANSMISSION:

Powershift transmission with 4-speeds in forward & reverse. Provides powershifts at any engine speed in any gear. All shifting is done with a single lever electrical control mounted on the steering column. Multiple-disc clutch packs operated by solenoid valve provide forward, neutral, reverse and speed selection. Equipped with oil cooler and filter. Torque converter has stall ratio of 2.2:1. Gradeability 63 percent.

Gear	Forward/Reverse	Travel	Drawbar
	Gear Ratios	Speed	Pull
First	5.72:1	6 km/h	7,030 kg
Second	3.23:1	11 km/h	3,945 kg
Third	1.77:1	21 km/h	2,085 kg
Fourth	1.00:1	35 km/h	1,135 kg

### AXLES:

#### Front:

Planetary drive/steer axle with 11.625:1 axle ratio. Differential is "No-Spin." Axle mounted rigidly to frame.

#### Optional 4-Wheel Drive

Planetary drive/steer axle with integral drop box input 11.625:1 axle ratio. Differential is "No-Spin." Mining and Industrial tires standard.

#### Rear:

#### 2-Wheel Drive:

Axle with 1-1/2° oscillation in either direction.

#### Optional 4-Wheel Drive:

Planetary drive/steer axle with 11.625:1 axle ratio. Differential is "Limited Slip." 1-1/2° oscillation degree in either direction.

Gear	Forward/Reverse	Travel	Drawbar
	Gear Ratios	Speed	Pull
First	5.72:1	5 km/h	8,890 kg
Second	3.23:1	10 km/h	4,990 kg
Third	1.77:1	18 km/h	2,675 kg
Fourth	1.00:1	32 km/h	1,495 kg

### STEERING:

Hydraulic steering unit with cylinders attached to each axle. Rear axle is the primary steer. An electric switch in the operator's compartment is used to select rear-wheel steering, four-wheel round steering or crab steering. Electronic sensors and control box automatically align the steering when a new mode is selected.

### BRAKES:

	2-Wheel Drive	4-Wheel Drive
Front	Internal wet disc	Internal wet disc
Rear	Drum type	Internal wet disc
Parking	Disc type	Disc type

### TIRES:

2-Wheel Drive 10.00 x 15, load range H bias, 16-ply rating.  
4-Wheel Drive 36 X 11-15, Mining & Industrial, 16 ply rating.

### CHASSIS:

#### Cargo Deck:

4.92 m<sup>2</sup> of deck area. 6,350 kg capacity on deck when load is centered over or between axles.<sup>1</sup> A storage box is located in front cargo deck. Steps located on front corners.

1. 6,350 kg allowed at creep speed of 3.2 km/h and 61 m maximum in 30 minutes.

#### Outriggers:

Four hydraulic outriggers of box beam construction. Independent controls for each outrigger. Each cylinder equipped with direct-connected holding valves. Outrigger pad dimension 23 cm x 30 cm.

#### Lifting Rings:

Lifting rings at each corner of cargo deck so sling can be attached for lifting crane.

### OPERATOR COMPARTMENT:

Operator's control station provides one-position access to all operating functions. Includes adjustable operator's seat, retracting seat belt, fire extinguisher and bubble level.

### ELECTRICAL:

#### 12 Volt System

#### Instrument Package:

Includes fuel and hourmeter. Also included are, warning lights for low oil and transmission pressure, turn signal, high beams, hazard lights, parking brake, hydraulic oil temperature, battery, check engine, stop engine, coolant temperature, outriggers and optional 4-wheel drive.

#### Lighting Package:

One pair headlights with Hi and Low beams, back-up lights, integral tail, brake, front and rear turn signals and emergency flasher switch at operator's station. 12V horn actuated by button on shifting control.

#### Back-Up Alarm:

Provides pulsating sound from 97 dB alarm when transmission is in reverse. Conforms to SAE J994b.

#### Outrigger Alarm System:

Two-tone alarm is activated when "outrigger down" controls are operated.

### HYDRAULIC SYSTEM:

Tandem pump, direct-driven by engine crankshaft, rated at 61 & 121 lp/m at rated RPM. Hydraulic oil tank capacity of 64.6 L.

### BOOM ASSEMBLY:

Three-section boom assembly equipped with bearing pads, double-acting hydraulic cylinders with direct-connected holding valves & boom angle indicator on each side of boom.

### Boom Rotation:

Heavy-duty ball bearing rotation gear with external teeth. Rotation is powered by hydraulic motor and worm gear drive.

### Boom Hoist:

Turret mounted planetary gear hoist hydraulically powered with a bare drum line pull of 4,535 kg at a line speed of 33.5 mp/m. Includes downhaul weight, swivel hook & sheave block for 2-part line and 38.1 m of 14.3 mm hoist rope.

### Anti-Two-Block Device:

Prevents damage to hoist rope and/or crane components from pulling load hook against tip.

### Sheave Block, Two-Part:

Single sheave block for 2-part line requirements.

### Rated Capacity Limiter:

Warns operator of impending overload with audible and visual signals. Prevents overload by stopping boom functions that cause overloads.

# IC-80-H

## Options

Listed below are brief descriptions of options available for this product.  
Consult the IC-80-H Engineering Spec for additional information.

### MODELS:

- IC-80-1H Industrial Crane** with  
6.5 m -2.49 m Boom Reach
- IC-80-2H Industrial Crane** with  
2.90 m - 7.33 m Boom Reach
- IC-80-3H Industrial Crane** with  
3.51 m - 9.14 m Boom Reach

### ENGINE:

- Spark Arrester Muffler**  
Installed in addition to std. muffler.
- Catalytic Converter**  
Reduces engine emissions.
- Engine Heater**  
Engine coolant heater installed to circulate warm water through engine. Plugs into 120 volt AC.

### AXLE & STEERING OPTIONS:

- 4-Wheel Steer & 2-Wheel Drive**
- 4-Wheel Steer & 4-Wheel Drive**  
(Diesel Engine Only)

### TIRE OPTIONS:

- Mining & Industrial Tires**
  - 36 x 11-15 , 16-Ply Rating
  - 36 x 11-15, Non Marking
- Solid Rubber Tires, 8.25 x 15**
- Foam Filling of Tires**
- Spare Tire & Wheel**
  - Radial
  - Bias
  - Mining & Industrial, 36 x 11-15
  - Mining & Industrial, Non Marking

### CHASSIS OPTIONS:

- Auxiliary Winch**  
Mounted behind front bumper, hydraulically driven with control in operator's console.
- Pintle Hook:**
  - Pintle Hook, Rear**
  - Pintle Hook, Front**
- Headlight and Taillight Grilles**  
Welded steel protective grilles for headlights and taillights.
- Rearview Mirrors**  
One mounted on right-hand deck stake and one mounted on left-hand deck stake.

### OPERATOR COMPARTMENT OPTIONS:

- Operator Guard**  
Tubular steel weldment with heavy expanded steel mesh top section.
- Operator Guard Cover**  
Clear vinyl cover which goes over Operator Guard, for inclement weather operations.
- All-Weather Cab**  
Rigid-mounted canopy section & removable hinged door. Includes heater, electric windshield wiper, one sliding glass window in the door & one in the right side of canopy. Defroster fan & dome light included.
- Cab Heater**  
Heater with two-speed fan for units without All Weather Cab.
- Windshield Washer**  
Includes reservoir pump and nozzle.
- Floor Mat**  
Vinyl mat with foam backing.
- Operator Suspension Seat**  
Provides additional operator comfort.
- Noise Reduction Kit**  
Includes floor mat, control valve and side panels of foam backed vinyl for noise reduction.
- Air Conditioning**  
Air Conditioner with R134 coolant.

### ELECTRICAL OPTIONS:

- Strobe Lights**  
Yellow strobe light mounted on each side of turret weight box.
- Boom Work Lights**  
One work light mounted to boom to light boom tip and one work light mounted to turret to light ground under boom tip.
- Work Lights-Rear**  
Two work lights recessed in rear bumper.

### BOOM ATTACHMENTS:

- Boom Extension, 3.09 m**  
Boom stowable.
- Boom Extension, 3.09 m, Offsettable**  
Same as above item, except the boom extension is offsettable to 3 different positions; 0 degrees (inline), 15 degrees and 30 degrees offset.
- Searcher Hook:**  
Nose Mount

Should you require an option or special equipment not listed please consult your dealer salesperson or BMC®.

**BRODERSON®**  
Manufacturing Corp.  
14741 West 106th Street  
Lenexa, KS 66215 USA

Tel (913) 888-0606  
Fax (913) 888-8431  
www.bmccranes.com

Dimensions and values shown are  
for reference purposes only.  
Specifications subject to change.

